

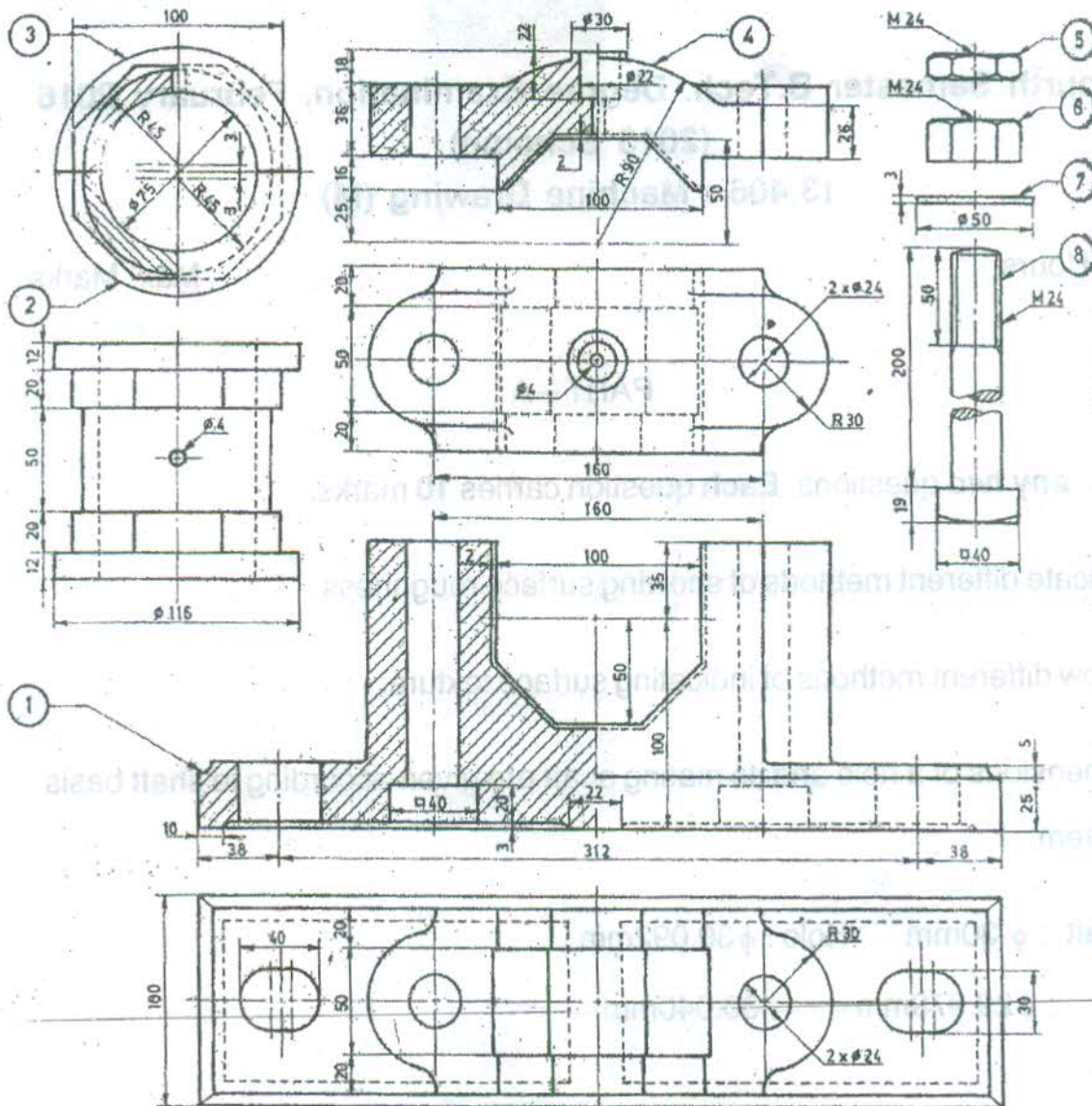

PART - B

4. Draw Sectional elevation, right half in section, plan and side view of the plummer block shown in figure. 80



(i)

ITEM LIST

Item	Description	Qty.	Material
1	Block	1	C. I.
2	Brass (Bottom)	1	Brass
3	Brass (Top)	1	Brass
4	Cover	1	C. I.
5	Locknut	2	M. S.
6	Nut	2	M. S.
7	Washer	2	M. S.
8	Bolt	2	M. S.

PLUMMER BLOCK